

## Dell EMC PowerEdge T140



The PowerEdge T140 is the practical entry-level 1-socket mini-tower server that is easy to use and keeps your data safe. It is ideal for growing businesses that primarily perform file and print, mail and messaging, and point of sale workloads.

© 2018 Dell Inc. or its subsidiaries. All rights reserved. Dell, EMC, and other trademarks are trademarks of Dell Inc. or its subsidiaries. Other trademarks may be trademarks of their respective owners.

2018 - 10

Rev. A00

# Contents

<b>1 Product overview.....</b>	<b>5</b>
Introduction.....	5
New technologies.....	5
<b>2 Product features.....</b>	<b>6</b>
Product comparison.....	6
Specifications.....	7
<b>3 Chassis views and features.....</b>	<b>9</b>
Front view of the system.....	9
Rear view of the system.....	10
Inside the system.....	11
Locating the Service Tag of your system.....	11
<b>4 Processor.....</b>	<b>13</b>
Processor features.....	13
Supported processors.....	13
Chipset.....	14
<b>5 Memory.....</b>	<b>16</b>
Supported memory.....	16
Memory speed.....	16
Memory population and configuration.....	16
<b>6 Storage.....</b>	<b>18</b>
Supported hard drives.....	18
Storage Controller .....	19
Optical drive.....	19
Tape drive.....	19
vFlash and BOSS card .....	19
Boot Optimized Storage Subsystem (BOSS).....	19
<b>7 Networking and PCIe.....</b>	<b>20</b>
PCIe slots.....	20
<b>8 Power and acoustics.....</b>	<b>21</b>
Power supply units.....	21
Acoustics.....	21
<b>9 Supported operating systems.....</b>	<b>23</b>
<b>10 Dell EMC OpenManage systems management.....</b>	<b>24</b>
iDRAC with Lifecycle controller.....	24

iDRAC features and comparison.....	25
Agent-free management.....	29
Agent-based management.....	29
Dell EMC consoles.....	29
Dell EMC OpenManage systems management tools, utilities and protocols.....	31
Integration with third-party consoles.....	32
OpenManage connections with third-party consoles.....	33
<b>11 Appendix A. Additional specifications.....</b>	<b>34</b>
Chassis dimensions.....	34
Video.....	34
USB ports.....	35
Hard drives.....	35
NIC ports.....	35
Environmental specifications.....	35
<b>12 Appendix B. Standards compliance.....</b>	<b>37</b>
<b>13 Appendix C Additional resources.....</b>	<b>38</b>
<b>14 Appendix D. Support and deployment services.....</b>	<b>39</b>
ProDeploy Enterprise Suite and Residency Services.....	39
ProDeploy Plus.....	39
ProDeploy.....	39
Basic Deployment.....	39
Residency Services.....	40
Deployment services.....	40
Remote Consulting Services.....	40
Data Migration Service.....	40
ProSupport Enterprise Suite.....	40
ProSupport Plus.....	41
ProSupport.....	41
ProSupport One for Data Center.....	41
Support Technologies.....	42
SupportAssist.....	42
TechDirect.....	42
Additional professional services.....	43
Dell Education Services.....	43
Dell EMC Global Infrastructure Consulting Services.....	43
Dell EMC Managed Services.....	43

# Product overview

## Introduction

The Dell EMC PowerEdge T140 is the practical entry-level 1-socket mini-tower server that is easy to use and secure.

## New technologies

The PowerEdge T140 is the practical entry-level 1-socket mini-tower server for growing businesses and organizations. The PowerEdge T140 is easy to use and helps keep your data safe to grow your business. Now with faster 6 core Intel® Xeon® processors, it helps run applications faster and support for full-feature remote management (iDRAC9), the T140 is also excellent for Remote Offices / Branch Offices (ROBO) of large institutions. Enhanced by quiet operation and compact mini-tower dimensions, the PowerEdge T140 1-socket tower server delivers the performance, efficiency and expandability needed for success.

The T140 is versatile enough to address many customer segments and workloads. Target workloads include:

- Small Businesses and organizations:
  - File and print, mail and messaging, point of sale, web serving, and other collaboration and productivity applications.
- ROBO: Applications and workloads specific to the particular industry, e.g. Retail, Healthcare, Finance, Education, etc.

**Table 1. Detailed information of new technologies**

New technologies	Description
<b>Intel® C246 series chipset</b>	Please refer to the <a href="#">chipset section</a> for details.
<b>Intel® Xeon® processor E-2100 Product Family</b>	The Intel® processor that works with Intel® C246 series chipset. The Xeon® E-2100 processor has increased core count and embedded PCIe lanes that will improve the IO performance and a lot more features.
<b>Next Generation SW RAID, PERC S140</b>	The new 14G 1-socket servers support the latest S140 software RAID along with H330 and H730P controller cards with improved functionality and faster performance. New SW RAID supports RAID 0, 1, 5 and 10.
<b>iDRAC 9</b>	The new embedded system management solution for 14G server features hardware and firmware inventory and alerting, in depth memory alerting, faster performance, dedicated gigabit port, email alerts, electronic licensing, editable user work notes log, and more. Dedicated iDRAC Direct microUSB port improves at-the-box management.

# Product features

## Product comparison

The following table shows the comparison between the PowerEdge T130 and the PowerEdge T140:

Feature	PowerEdge T130	PowerEdge T140
<b>Processor</b>	<ul style="list-style-type: none"> <li>Intel® Xeon® processor E3-1200 v6 product family</li> <li>Intel® Core™ i3</li> <li>Intel® Pentium®</li> <li>Intel® Celeron®</li> </ul>	<ul style="list-style-type: none"> <li>Intel® Xeon® processor E-2100 product family</li> <li>Intel® Core™ i3</li> <li>Intel® Pentium®</li> <li>Intel® Celeron®</li> </ul>
<b>Front Side Bus</b>	<ul style="list-style-type: none"> <li>DMI 3.0</li> </ul>	<ul style="list-style-type: none"> <li>DMI 3.0</li> </ul>
<b>Number of processors</b>	<ul style="list-style-type: none"> <li>1</li> </ul>	<ul style="list-style-type: none"> <li>1</li> </ul>
<b>Number of cores</b>	<ul style="list-style-type: none"> <li>Up to 4 cores</li> </ul>	<ul style="list-style-type: none"> <li>Up to 6 cores</li> </ul>
<b>L2/L3 cache</b>	<ul style="list-style-type: none"> <li>2.0 MB per core 4 MB or 8 MB</li> </ul>	<ul style="list-style-type: none"> <li>2.0 MB per core 8 MB or 12 MB</li> </ul>
<b>Chipset</b>	<ul style="list-style-type: none"> <li>Intel® C236 chipset</li> </ul>	<ul style="list-style-type: none"> <li>Intel® C246 chipset</li> </ul>
<b>DIMMs</b>	<ul style="list-style-type: none"> <li>4 UDIMMS DDR4 Up to 2400MT/s</li> </ul>	<ul style="list-style-type: none"> <li>4 UDIMMS DDR4 Up to 2666MT/s</li> </ul>
<b>Min/Max RAM</b>	<ul style="list-style-type: none"> <li>4GB/64GB</li> </ul>	<ul style="list-style-type: none"> <li>8GB/64GB</li> </ul>
<b>Hard drive bays</b>	<ul style="list-style-type: none"> <li>4x 3.5" cabled</li> </ul>	<ul style="list-style-type: none"> <li>4x 3.5" cabled</li> </ul>
<b>Hard drive types</b>	<ul style="list-style-type: none"> <li>3.5" Enterprise SATA 7.2K HDDs</li> <li>3.5" Near Line SAS 7.2K HDDs</li> <li>3.5" 7.2K SATA Entry Drives</li> </ul>	<ul style="list-style-type: none"> <li>3.5" Enterprise SATA 7.2K HDDs</li> <li>3.5" Near Line SAS 7.2K HDDs</li> <li>3.5" 7.2K SATA Entry Drives</li> </ul>
<b>External drive bay(s)</b>	<ul style="list-style-type: none"> <li>1x slim ODD 9.5mm</li> </ul>	<ul style="list-style-type: none"> <li>1x slim ODD 9.5mm</li> </ul>
<b>Embedded hard drive controller</b>	<ul style="list-style-type: none"> <li>Chipset based SATA PERC S130 (Embedded SW RAID)</li> </ul>	<ul style="list-style-type: none"> <li>Chipset based SATA PERC S140 (Embedded SW RAID)</li> </ul>
<b>Optional storage controller</b>	<ul style="list-style-type: none"> <li>Non-RAID: 12GB SAS HBA</li> <li>RAID: PERC H330, PERC H730, PERC H830</li> </ul>	<ul style="list-style-type: none"> <li>Non-RAID: 12GB SAS HBA, PERC HBA330</li> <li>RAID: PERC H330, PERC H730P</li> </ul>
<b>Boot Optimized Storage Subsystem (BOSS)</b>	Not Supported	<ul style="list-style-type: none"> <li>2x M.2 240GB (RAID 1 or No RAID) 1x M.2 240GB (No RAID only)</li> </ul>
<b>Server management</b>	<ul style="list-style-type: none"> <li>Dell Open Manage featuring Dell Management Console</li> <li>Lifecycle Controller 3.0</li> <li>iDRAC8 Enterprise</li> </ul>	<ul style="list-style-type: none"> <li>Dell Open Manage featuring Dell Management Console</li> <li>Lifecycle Controller 3.0</li> <li>iDRAC9 Enterprise</li> </ul>
<b>I/O slots</b>	<ul style="list-style-type: none"> <li>1x8 Gen3 (x16 connector) FH/HL</li> </ul>	<ul style="list-style-type: none"> <li>1x8 Gen3 (x16 connector) FH/HL</li> </ul>

Feature	PowerEdge T130	PowerEdge T140
	<ul style="list-style-type: none"> <li>1x4 Gen3 (x8 connector) FH/HL</li> <li>1x4 Gen3 (x8 connector) FH/HL</li> <li>1x1 Gen3 (x1 connector) FHHL</li> </ul>	<ul style="list-style-type: none"> <li>1x8 Gen3 (x8 connector) FH/HL</li> <li>1x4 Gen3 (x8 connector) FH/HL</li> <li>1x1 Gen3 (x1 connector) FH/HL</li> </ul>
<b>NIC/LOM</b>	<ul style="list-style-type: none"> <li>2 X 1GbE LOM</li> </ul>	<ul style="list-style-type: none"> <li>2 X 1GbE LOM</li> </ul>
<b>USB</b>	<ul style="list-style-type: none"> <li>Rear: 2 USB 3.0, 4 USB 2.0</li> <li>Front: 1 USB 2.0, 1 USB 3.0</li> <li>Internal: 1 USB 3.0</li> </ul>	<ul style="list-style-type: none"> <li>Rear: 2 USB 3.0, 4 USB 2.0</li> <li>Front: 1 USB 3.0, 1 Micro USB 2.0 (Dedicated iDRAC direct)</li> <li>Internal: 1 USB 3.0</li> </ul>
<b>Power supplies</b>	<ul style="list-style-type: none"> <li>Non-Redundant D5 290W Bronze EPA (Auto sensing)</li> </ul>	<ul style="list-style-type: none"> <li>Non-Redundant D5 365W Gold EPA (Auto sensing)</li> </ul>
<b>Fans</b>	<ul style="list-style-type: none"> <li>Non-redundant, non-hot swappable</li> </ul>	<ul style="list-style-type: none"> <li>Non-redundant, non-hot swappable</li> </ul>
<b>Form factor</b>	<ul style="list-style-type: none"> <li>Mini Tower</li> </ul>	<ul style="list-style-type: none"> <li>Mini Tower</li> </ul>
<b>Dimension (HxWxD)</b>	<ul style="list-style-type: none"> <li>Height 14.17 in / 36.0 cm</li> <li>Width 6.89 in / 17.5 cm</li> <li>Depth 17.9 in / 45.4 cm</li> </ul>	<ul style="list-style-type: none"> <li>Height 14.17 in / 36.0 cm</li> <li>Width 6.89 in / 17.5 cm</li> <li>Depth 17.9 in / 45.4 cm</li> </ul>
<b>Weight</b>	<ul style="list-style-type: none"> <li>Max 24.91lbs or (11.3 Kgs)</li> </ul>	<ul style="list-style-type: none"> <li>Max 26.10lbs or (11.84 Kgs)</li> </ul>

## Specifications

The following table shows the specifications for the PowerEdge T140:

**Table 2. Product specifications**

Feature	Specifications
<b>Form Factor</b>	<ul style="list-style-type: none"> <li>Mini Tower</li> </ul>
<b>Processors</b>	<ul style="list-style-type: none"> <li>Intel® Xeon® processor E-2100 product family</li> <li>Intel® Core™ i3 8100 processor</li> <li>Intel® Pentium® G5500 processor</li> <li>Intel® Celeron G4900 processor</li> </ul>
<b>Processor sockets</b>	<ul style="list-style-type: none"> <li>1</li> </ul>
<b>Front Side Bus or HyperTransport</b>	<ul style="list-style-type: none"> <li>DMI</li> </ul>
<b>Cache</b>	<ul style="list-style-type: none"> <li>2.0 MB per core</li> <li>8 MB or 12 MB</li> </ul>
<b>Chipset</b>	<ul style="list-style-type: none"> <li>Intel® C246 Chipset</li> </ul>
<b>Memory</b>	<ul style="list-style-type: none"> <li>Up to 64GB (4 DIMM Slots)</li> <li>8GB/16GB 2666MT/s Unbuffered with ECC only</li> <li>Min/Max RAM: 8GB/64GB</li> </ul>
<b>I/O Slots</b>	<ul style="list-style-type: none"> <li>4 Gen3 PCIe slots: <ul style="list-style-type: none"> <li>One x8 slots (one with x16 connectors)</li> <li>Two x4 slot (with x8 connector)</li> </ul> </li> </ul>

Feature	Specifications
<b>RAID Controller</b>	<ul style="list-style-type: none"> <li>• One x1 slot</li> <li>• Internal controllers: PERC S140, PERC H330, PERC H730P</li> <li>• External HBAs (non-RAID): 12GB SAS HBA</li> </ul>
<b>Drive bays</b>	<ul style="list-style-type: none"> <li>• Up to four 3.5" cabled SAS or SATA drives</li> </ul>
<b>Hard drives</b>	<ul style="list-style-type: none"> <li>• 3.5" Enterprise SATA 7.2K HDDs</li> <li>• 3.5" Near Line SAS 7.2K HDDs</li> <li>• 3.5" 7.2K SATA Client Drives</li> <li>• Capacity: 1 TB ,2 TB ,4 TB (4TB requires PERC H330 or H730P)</li> </ul>
<b>Embedded LOM/NIC</b>	<ul style="list-style-type: none"> <li>• Integrated BROADCOM BCM5720 Gigabit Ethernet Controller</li> </ul>
<b>Communications</b>	<ul style="list-style-type: none"> <li>• Optional add-in NICs: <ul style="list-style-type: none"> <li>– 1GB Intel (Dual) Powerville Troi-Stony Dual port 1Gb Base-T adapter - FH</li> <li>– 1GB Intel (Quad) Powerville Lore-Stony Quad port 1Gb Base-T adapter - FH</li> <li>– 1GB Broadcom (Dual) 5720 Bashir Dual port 1Gb Base-T adapter - FH</li> <li>– 1GB Broadcom (Quad) 5719 Cardassia Quad port 1Gb Base-T adapter - FH</li> </ul> </li> </ul>
<b>Power supply</b>	<ul style="list-style-type: none"> <li>• Cabled 365W Gold (100–240 V AC)</li> </ul>
<b>Availability</b>	<ul style="list-style-type: none"> <li>• ECC Memory, ADD-in RAID, TPM/CTPM</li> </ul>
<b>Video</b>	<ul style="list-style-type: none"> <li>• Integrated Matrox G200 with iDRAC9</li> </ul>
<b>Remote Management</b>	<ul style="list-style-type: none"> <li>• Base Management Console, IDRAC Express and IDRAC Enterprise (Upsell option)</li> </ul>
<b>Systems Management</b>	<ul style="list-style-type: none"> <li>• Dell Open Manage featuring Dell Management Console</li> <li>• Lifecycle Controller 3.0</li> <li>• iDRAC9 Enterprise</li> </ul>
<b>Featured Database Applications</b>	<ul style="list-style-type: none"> <li>• Microsoft® SQL Server® solutions</li> </ul>



# Chassis views and features

## Front view of the system

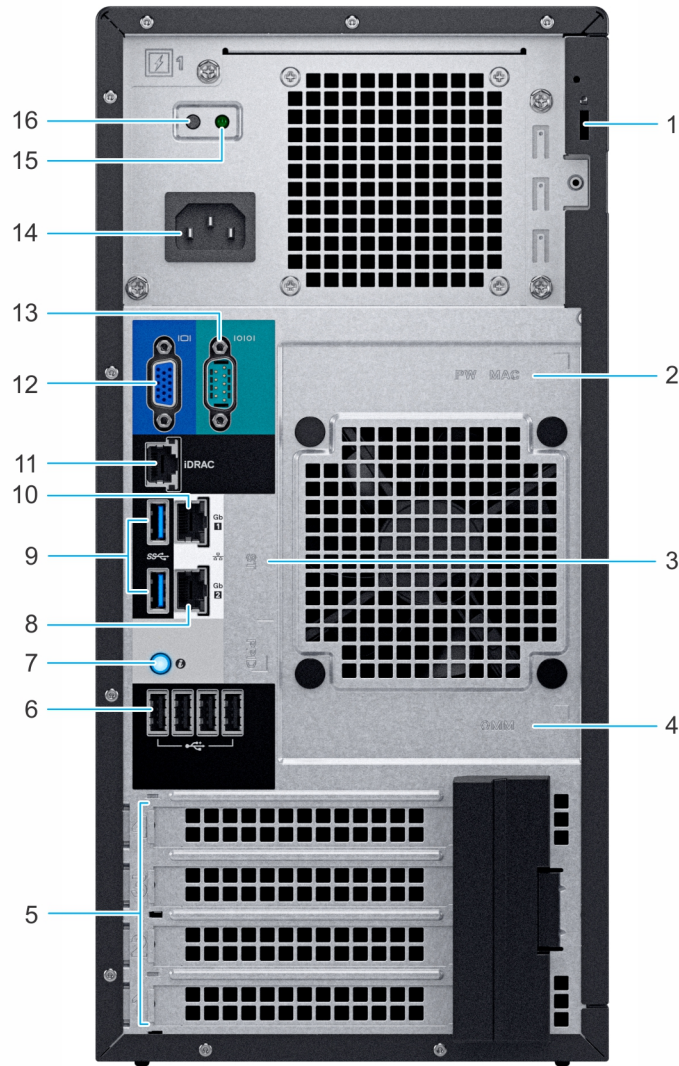

**Figure 1. Front view of the system**

- |                             |                                   |
|-----------------------------|-----------------------------------|
| 1. Power button             | 2. System health and ID indicator |
| 3. USB 3.0 port             | 4. iDRAC direct micro USB port    |
| 5. Optical drive (optional) |                                   |

For more information about the ports, see the [Ports and connectors specifications](#) section.

## Rear view of the system



**Figure 2. Rear view of the system**

- |     |  |     |   |
|-----|--|-----|---|
| 1.  | Security Cable Lock                          | 2.  | iDRAC MAC address and iDRAC secure password label |
| 3.  | Service Tag, Express Service Code, QRL label | 4.  | OpenManage Mobile (OMM) label                     |
| 5.  | PCIe expansion card slots (4)                | 6.  | USB 2.0 port (4)                                  |
| 7.  | System identification button                 | 8.  | NIC port (Gb 2)                                   |
| 9.  | USB 3.0 ports (2)                            | 10. | NIC port (Gb 1)                                   |
| 11. | iDRAC dedicated NIC port                     | 12. | VGA port  |
| 13. | Serial port                                  | 14. | Power supply unit                                 |
| 15. | PSU Built-in Self Test (BIST) LED            | 16. | PSU Built-in Self Test (BIST) Button              |

 **NOTE:** For more information about the ports and connectors, see the [Ports and connectors specifications](#) section.

## Inside the system

 **CAUTION:** Many repairs may only be done by a certified service technician. You should only perform troubleshooting and simple repairs as authorized in your product documentation, or as directed by the online or telephone service and support team. Damage due to servicing that is not authorized by Dell is not covered by your warranty. Read and follow the safety instructions that are shipped with your product.

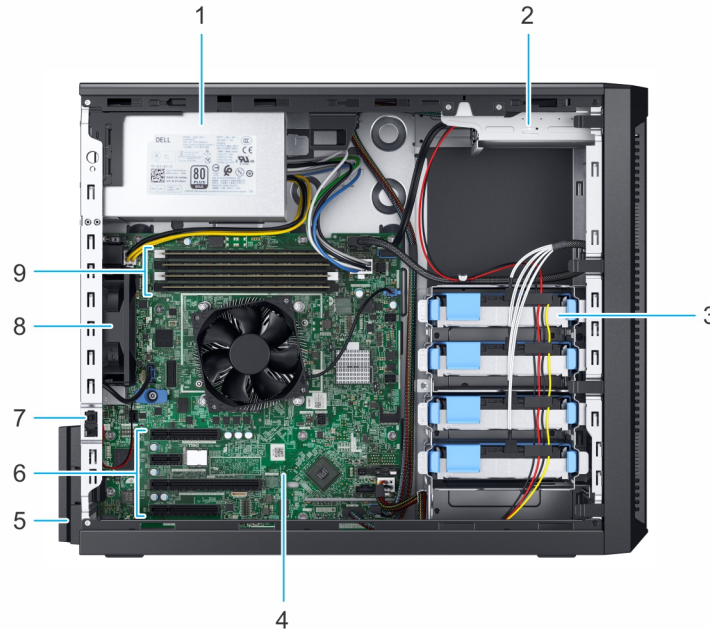
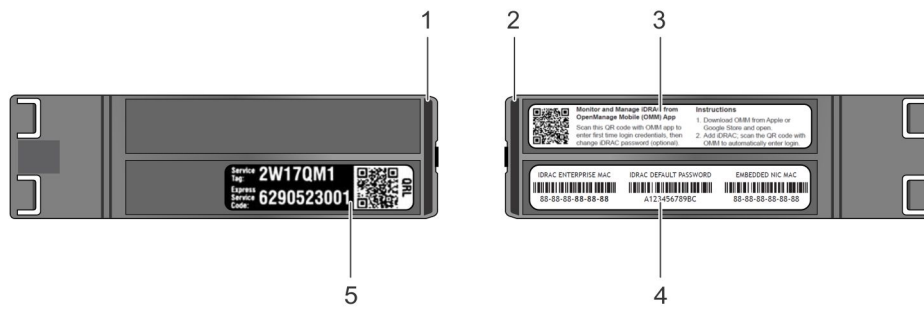

**Figure 3. Inside the system**

- |                                   |                                  |
|-----------------------------------|----------------------------------|
| 1. Cabled Power Supply Unit (PSU) | 2. Optical drive                 |
| 3. Cabled drives (4)              | 4. System board                  |
| 5. Expansion card retention latch | 6. PCIe expansion card slots (4) |
| 7. Intrusion switch               | 8. Fan                           |
| 9. Memory module sockets          |                                  |

## Locating the Service Tag of your system

You can identify your system using the unique Express Service Code and Service Tag. Pull out the information tag in front of the system to view the Express Service Code and Service Tag. Alternatively, the information may be on a sticker on the chassis of the system. The mini Enterprise Service Tag (EST) is found on the back of the system. This information is used by Dell to route support calls to the appropriate personnel.



**Figure 4. Locating Service Tag of your system**

1. Information tag (top view)
3. OpenManage Mobile (OMM) label
5. Service Tag
2. Information tag (back view)
4. iDRAC MAC address and iDRAC secure password label

# Processor

The PowerEdge T140 is the 1-socket, entry-level tower server based on the Intel® Xeon® processor E-2100 product family.

## Processor features

The following table lists the features of the Intel® Xeon® processor E-2100 product family:

- Up to six execution cores per processor
- Four DMI3 lanes
- 16 PCIe Gen 3 links capable of 8.0 GT/s
- Socket H4, LGA package (LGA1151)
- Integrated 2 channel DDR4 memory controller
- Execute Disable Bit
- Support Turbo Boost Technology 2.0
- Increases CPU frequency if operating below thermal, power, and current limits
- Intel® Virtualization Technology (Intel® VT)

 **NOTE: We do not support graphics with E-2100 processors, Graphics cannot be enabled on Dell EMC servers using this processor due to technical restrictions.**

## Supported processors

The following table lists the supported processors for the PowerEdge T140:

Model	Speed (GHz)	Power (Watts)	Cores	L3 Cache (MB)	Threads	Turbo	Max Memory Speed (MT/s)	Hyper-threading
E-2186G	3.8	95	6	12	12	Yes	2666	Yes
E-2176G	3.7	80	6	12	12	Yes	2666	Yes
E-2174G	3.8	71	4	8	8	Yes	2666	Yes
E-2146G	3.5	80	6	12	12	Yes	2666	Yes
E-2144G	3.6	71	4	8	8	Yes	2666	Yes
E-2136	3.3	80	6	12	12	Yes	2666	Yes
E-2134	3.5	71	4	8	8	Yes	2666	Yes
E-2126G	3.3	80	6	12	6	Yes	2666	No
E-2124	3.3	71	4	8	4	Yes	2666	No
Core i3 8100	3.6	65	4	6	4	No	2666	No
Pentium G5500	3.8	54	2	4	2	No	2666	No

Model	Speed (GHz)	Power (Watts)	Cores	L3 Cache (MB)	Threads	Turbo	Max Memory Speed (MT/s)	Hyper-threading
Celeron G4900	3.1	54	2	2	2	No	2666	No

## Chipset

The following table shows the high level features supported by the C246 chipset implemented on the PowerEdge T140:

PCH feature	C246	T140
TXT	Y	Y
Node Manager	Y	N
ECC	Y	Y
FlexIO - USB3.0 - 10 (means 6 is enough)	10	3
USB 2.0	4	4
FlexIO - 8 SATA ports	8	5
FlexIO - SATA Express	3	0
FlexIO - PCIE 3.0 ports - additional required	20	8
SPI (MB) FW image	7	UI
Intel vPRO/AMT11	Y	N
Rapid Strorage technology	Y	N
Rapid Strorage technology enterprise	Y	N
Data Center Graphics supported displays	N	N
Int. Gbe MAC	Y	N
eSPI	Y	N
IO Flex - ability to change SATA/PCIE/USB	Y	N
Software Guard Extensions (SGX)	N	Y

The following table shows the features supported by the T140 chipset:

**Table 3. Chipset features**

Features	Description
<b>DMI interface</b>	Direct Media Interface 3 (DMI3) connects the CPU1 to the chipset. DMI3 is similar to a four lane PCI Express supporting a speed of 8 GT/s per lane.
<b>PCI Express interface</b>	PCI Express Generation 3 (PCIe Gen3) is capable of 8 GT/s bit rate (compared to PCIe Gen 2's 5 GT/s) per lane. Because PCIe Gen3 uses a "scrambling" encoding instead of PCIe Gen2's

Features	Description
<b>AHCI</b>	<p>8b/10b encoding, it is able to have double the bandwidth of PCIe Gen2.</p> <p>The PCIe Gen 3 will be fully compatible with prior generations of this technology, from software to clocking architecture to mechanical interfaces.</p> <p>The chipset SATA controller provides hardware support for Advanced Host Controller Interface (AHCI), a standardized programming interface for SATA host controllers developed through a joint industry effort. Platforms supporting AHCI may take advantage of performance features such as port independent DMA Engines—each device is treated as a master—and hardware-assisted native command queuing.</p>
<b>Low Pin Count Interface (LPC)</b> <b>Serial Peripheral Interface (SPI)</b>	<p>The chipset implements an LPC interface.</p> <p>The chipset provides one Serial Peripheral Interface (SPI). The interface implements 3 Chip Select signals (CS#), allowing up to two flash devices and one TPM device to be connected to the PCH. The CS0# and CS1# are used for flash devices and CS2# is dedicated to TPM.</p>
<b>Advanced Programmable Interrupt Controller (APIC)</b>	<p>The I/O APIC within the chipset supports 40 APIC interrupts. Each interrupt has its own unique vector assigned by software.</p>
<b>Real Time Clock (RTC)</b>	<p>The Real-Time Clock (RTC) performs two key functions—keeping track of the time of day and storing system data, even when the system is powered down. The RTC operates on a 32.768-KHz crystal and a 3V battery.</p>
<b>General-Purpose Input/Output (GPIO)</b>	<p>GPIO Serial Expander (GSX) is the capability provided by the chipset to expand the GPIOs on a platform that needs more GPIOs than the ones provided by the PCH. The solution requires external shift register discrete components.</p>
<b>System Management Bus (SMBus 2.0)</b>	<p>The chipset provides a System Management Bus (SMBus) 2.0 host controller as well as an SMBus Slave Interface. The chipset is also capable of operating in a mode in which it can communicate with I2C compatible devices. The host SMBus controller supports up to 100- KHz clock speed.</p>
<b>JTAG Boundary-Scan</b>	<p>This section contains information regarding the chipset testability signals that provides access to JTAG, run control, system control, and observation resources. PCH JTAG (TAP) ports are compatible with the IEEE Standard Test Access Port and Boundary Scan Architecture 1149.1 and 1149.6 Specification, as detailed per device in each BSDL file. JTAG Pin definitions are from IEEE Standard Test Access Port and Boundary-Scan.</p>

# Memory

The PowerEdge T140 supports up to 4 DDR4 DIMMs. The T140 is designed to support the socket H4, Intel® Xeon® processor E-2100 product family CPU, which has 2 memory channels per CPU, with each channel supporting up to 2 DIMMs.

The maximum system population at launch will be 64GB. The minimum system population is one 8GB DIMM.

## Supported memory

The PowerEdge T140 supports memory with the following features:

- Unbuffer (UDIMM) ECC DDR4 technology
- Each channel carries 64 data and 8 ECC bits
- Up to 64 GB of UDIMM memory (4 x 16GB UDIMM)
- Up to 2666 MT/s DIMMs
- Flexible Memory Configuration
- ODT (On Die Termination)
- Clock gating (CKE) to conserve power when DIMMs are not accessed
- DIMMs enter a low power self-refresh mode
- I<sup>2</sup>C access to SPD EEPROM for access to thermal sensors
- Memory Optimized (Independent Channel) Mode
- 100% Single Bit Error Correction
- Memory Off-lining is NOT supported.

## Memory speed

The PowerEdge T140 supports 2666MT/s DDR4 memory. This system will run all memory on all CPUs and channels at the same speed and voltage. By default the system will run at the highest speed for the lowest voltage of the worst case channel DIMM configuration.

The operating speed of the system is determined by:

- Supported speed of DIMMs
- DIMM configuration on any channel
- Max speed supported by the CPU
- Speed request by user in BIOS setup screen

The operating voltage of the system is determined by:

- Voltages supported by the DIMMs which is 1.2V.
- Voltages supported by the platform.

## Memory population and configuration

The following table shows the supported memory configurations for the PowerEdge T140:



DIMM Speed	DIMM Type	DIMM Capacity (GB)	Ranks per DIMM	Data Width	SDDC Support	DIMM Volts
2666	UDIMM	8	1	x8	Advanced ECC	1.2
2666	UDIMM	8	1	x8	Advanced ECC	1.2
2666	UDIMM	16	1	x8	Advanced ECC	1.2
2666	UDIMM	16	1	x8	Advanced ECC	1.2
2400	UDIMM	4	1	x8	Advanced ECC	1.2
2400	UDIMM	8	1	x8	Advanced ECC	1.2
2400	UDIMM	8	1	x8	Advanced ECC	1.2
2400	UDIMM	16	2	x8	Advanced ECC	1.2
2400	UDIMM	16	2	x8	Advanced ECC	1.2
2133	UDIMM	4	1	x8	Advanced ECC	1.2
2133	UDIMM	4	1	x8	Advanced ECC	1.2
2133	UDIMM	8	2	x8	Advanced ECC	1.2
2133	UDIMM	8	1	x8	Advanced ECC	1.2
2133	UDIMM	16	2	x8	Advanced ECC	1.2
2133	UDIMM	16	2	x8	Advanced ECC	1.2

The following table shows the memory populations and system speed:

**Table 4. Memory populations and system speed**

DIMM Type	DIMM Ranking	Capacity	DIMM Rated voltage	1 DIMM per channel	2 DIMMs per channel
UDIMM	1R/2R	8GB, and 16GB	DDR4 (1.2V)	2666	2666

## Storage

The PowerEdge T140 supports 4 x 3.5-inch cabled hard drive configuration. The T140 will offer “Entry” as well as “Enterprise” hard drives. It is extremely important to set customer expectations around proper usage. Using Entry drives in improper usage pattern will result in risk to smooth operation and customer satisfaction. It is key to select the hard drive class that balances customer budget, performance and reliability, and that delivers worry-free computing and complete satisfaction.

Recommend/select Entry level hard drives vs. Enterprise level hard drives based on customer usage pattern:

- Entry drives are designed for customer applications with less intensive workload rating
- Entry level hard drives are designed for a 8x5 days/week operation
- Enterprise level hard drives are designed for a 24x7 operating environment

Entry level hard drive restrictions

- Entry level hard drives and Enterprise level hard drives cannot be mixed
- Cannot be ordered with Software Raid or Hardware Raid. Must be selected in a NO RAID configuration
- Must not be used if the customer usage patterns require a workload rating that exceeds 55 TB/year
- May induce compatibility issues depending on the OS due to the “advanced format”
- Entry level SATA hard drives in PowerEdge systems carry lesser of either a 1-year limited hardware warranty or the length of the limited hardware warranty for the Dell EMC system with which the hard drive is shipped.

The following table shows the differences between entry level hard drives and the enterprise level hard drives:

Feature	Entry level SATA HDDs	Enterprise level SATA HDDs
RPM	7200 RPM	7200 RPM
SATA Interface	6 G b / s	6 G b / s
HDD Sector Format	512 byte AF (advanced format)	512 byte
UBER (unrecovered error rate)	1x10 14	1x10 15
Performance Variation	u p t o + / - 35 %	+ / - 5 %
Vibration RV (Radians/sec/sec )	5.5 up to 300 Hz	12.5 up to 1500 Hz

## Supported hard drives

The PowerEdgeT140 provides scalable storage that enables you to adapt your workload and operational demands. The drive bay supports up to four 3.5-inch SATA/SAS drives.

**Table 5. Supported Drives - SAS and SATA**

Form Factor	Type	Speed	Rotational Speed	Capacities
3.5-inch	SATA	6 Gbps	7.2 K	1 TB, 2 TB, 4 TB
	SAS	12 Gbps	7.2 K	2 TB, 4 TB

## Storage Controller

Dell EMC's RAID controller options offer performance improvements, including the MiniPERC solution. Mini PERC provides a base RAID HW controller without consuming a PCIe slot by using a small form factor and high density connector to the base planar.

The new PERC controller offerings leverage heavily on previous generation PERC family. The premium performance PERC series controller drives better IOPs and enhanced the SSD performance.

**Table 6. PERC series controller offerings**

Performance Level	Controller & Description
Entry	S140 SW RAID SATA
Value	HBA330 (Internal) 12Gbps SAS HBA (External) Memory: None x8 12 Gb SAS x8 PCIe 3.0 H330
Value Performance	H730P Memory: 2GB, NV 72-bit, 866MHz x8 12 Gb SAS x8 PCIe 3.0

## Optical drive

The PowerEdge T140 will support up to one internal optical drives, and optional external USB DVD-ROM including ability to boot from.

## Tape drive

The PowerEdge T140 do not support internal tape drives due to the form factor. However, external tape backup devices will be supported. The list below shows the supported external tape drives:

- LTO-6 SAS
- LTO-7 SAS
- LTO-8 SAS

## vFlash and BOSS card

A SD vFlash card is a Secure Digital (SD) card that plugs into the SD vFlash card slot in the iDRAC port card. It provides persistent on-demand local storage and a custom deployment environment that enables automation of server configuration, scripts, and imaging. It emulates USB device(s).

### Boot Optimized Storage Subsystem (BOSS)

BOSS is offered as a means of booting servers to a full OS when:

- A solution such as IDSDM may be desired, but the target OS for BOSS is a fullOS (not just a hypervisor)
- The user needs to maximize their number of drive bays

BOSS cards take up a PCIe slot and are not hot-plug capable. 1x or 2x 240GB modules are available. Dual (2x) module configs can be set up for either RAID 1 or No RAID. Single (1x) module configs can only be set up in a No RAID config.

## Networking and PCIe

The following lists the supported add in communication cards:

- 1GB Intel (Dual) Powerville Troi-Stony Dual port 1Gb Base-T adapter - FH
- 1GB Intel (Quad) Powerville Lore-Stony Quad port 1Gb Base-T adapter- FH
- 1GB Broadcom (Dual)5720 Bashir Dual port 1Gb Base-T adapter- FH
- 1GB Broadcom (Quad) 5719 Cardassia Quad port 1Gb Base-T adapter - FH

### PCIe slots

The PowerEdge T140 chipset provides four PCI Express expansion slots as follows:

- Slot 1 : x8 PCIe Gen3 for FH/HL from CPU (x8 lanes)
- Slot 2 : x16 PCIe Gen3 for FH/HL from CPU (x8 lanes)
- Slot 3 : x1 PCIe Gen3 for FH/HL from PCH (x1 lanes)
- Slot 4 : x8 PCIe Gen3 for FH/HL from PCH (x4 lanes)

The following table shows the PCIe slot location and specifications:

PCI Slot	Mechanical	Electrical	Height	Length
1	PCIe x 8	PCIe x 8 Gen 3	Full Height	Half Length
2	PCIe x16	PCIe x 8 Gen 3	Full Height	Half Length
3	PCIe x 1	PCIe x 1 Gen 3	Full Height	Half Length
4	PCIe x 8	PCIe x 4 Gen 3	Full Height	Half Length

The following table shows the dimensions of the PCI cards:

Slots	Height	Length
Slot 1 (standard height, half length card)	111.15 mm (4.376 inches) maximum	167.65 mm (6.600 inches) maximum
Slot 2 (standard height, half length card)	111.15 mm (4.376 inches) maximum	167.65 mm (6.600 inches) maximum
Slot 3 (standard height, half length card)	111.15 mm (4.376 inches) maximum	167.65 mm (6.600 inches) maximum
Slot 4 (standard height, half length card)	111.15 mm (4.376 inches) maximum	167.65 mm (6.600 inches) maximum

# Power and acoustics

## Power supply units

The power supply subsystem is formed with a AC-DC cable power supply. The power supply provides +12V and +12Vaux for non-redundant design. There are several voltage regulators in the system to supply different voltage levels needed by different logic devices.

The following table shows the heat dissipation of the power supply units:

**Table 7. Heat dissipation**

Heat dissipation	989 BTU/hr maximum (290W power supply)
Voltage	100-240 V AC, autoranging, 50/60 Hz

## Acoustics

The PowerEdge T140 is a tower server appropriate for quiet office environment. The acoustical output is not noticeable under idle or typical operating condition. Acoustical performance for two configurations are provided: typical and feature rich. The following tables contains a summary of the configuration and acoustical performance of the PET140. Each configuration has been tested according to Dell EMC acoustical standards for tower servers.

Configuration	Minimum	Typical	Feature rich
CPU Type	Intel E2124	Intel E2124	Intel E2146G
CPU TDP	71 W	71 W	80 W
CPU Quantity	1	1	1
Memory Type	8GB, UDIMM	16GB, UDIMM	16GB, UDIMM
DIMM Quantity	1	2	2
HDD Type	7.2K RPM SATA	7.2K RPM SATA	7.2K RPM SATA
HDD Quantity	1	2	4
PSU Type	365W Cabled	365W Cabled	365W Cabled
PSU Quantity	1	1	1
Internal PERC	None	None	PERC H330

**Table 8. Acoustical performance: Idle/operating at 25°C ambient**

Configuration	Minimum	Typical	Feature rich
LwA-UL <sup>2</sup> (Bels)	Idle	3.6	3.7
	Operating	3.8	4.8
LpA <sup>3</sup> (dBA)	Idle	22	23
	Operating	27	32

Configuration	Minimum	Typical	Feature rich
Prominent tones	No prominent tones in Idle and Operating		

**Table 9. Acoustical performance: Idle/operating at 28°C ambient**

Configuration	Minimum	Typical	Feature rich
LwA-UL <sup>2</sup> (Bels)	3.9	3.9	3.9
LpA <sup>3</sup> (dBA)	26	26	26

**Table 10. Acoustical performance: Max loading at 35°C ambient**

Configuration	Minimum	Typical	Feature rich
LwA-UL <sup>2</sup> (Bels)	5.2	5.2	5.2
LpA <sup>3</sup> (dBA)	36	36	36

# Supported operating systems

The list below are the supported operating systems for the PowerEdge T140:

- Windows 2019 with Hyper-V
- Windows 2019 Essentials
- Windows 2016 with Hyper-V
- Windows 2016 Essentials
- Windows 2012 R2 Enterprise
- Windows 2012 R2 Standard
- RHEL 7.5
- SLES 15
- Ubuntu Server 18.04.1
- Citrix XenServer 7.1
- VMWare ESXi 6.7
- VMWare ESXi 6.5

# Dell EMC OpenManage systems management

Whether your IT environment consists of a few servers or a few thousand servers, Dell EMC OpenManage systems management solutions provide comprehensive management for evolving IT environments. OpenManage is based on open standards and provides agent-based and agent-free server lifecycle management functionality for Dell EMC PowerEdge servers. OpenManage solutions help you automate and streamline essential hardware management tasks.

Start with a firm foundation for efficient hardware management using OpenManage tools, utilities and management consoles. OpenManage systems management solutions consist of a combination of embedded management features and software products that help you automate and simplify the entire server lifecycle: deploy, update, monitor and maintain. OpenManage solutions are innovatively designed for simplicity and ease of use to help you reduce complexity, save time, achieve efficiency, control costs and empower productivity. OpenManage centers around efficient management of server lifecycle.

## The Dell EMC OpenManage Portfolio

**Simplifying hardware management through ease of use, intelligent automation and integrated security**

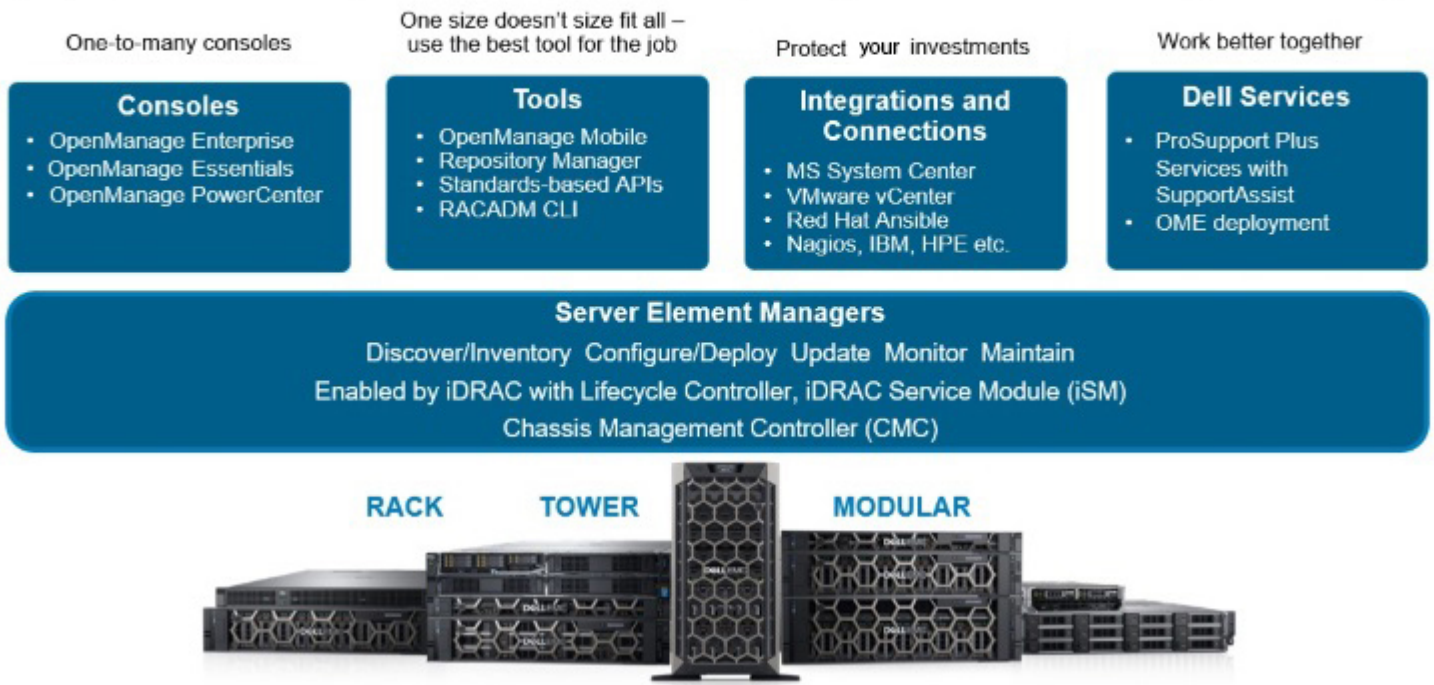

**Figure 5. Server lifecycle management operations**

### iDRAC with Lifecycle controller

The integrated Dell Remote Access Controller 9 (iDRAC9) with Lifecycle Controller is embedded within every Dell EMC PowerEdge server and provides functionality that helps IT administrators deploy, update, monitor, and maintain servers with no need for any additional software to be installed. iDRAC functions regardless of operating system or hypervisor presence because from a pre-OS or bare-metal state, iDRAC is ready to work because it is embedded within each server from the factory.



## iDRAC features and comparison

The PowerEdge T140 supports the following iDRAC licenses – Basic (default), Express (upgrade) and Enterprise (upgrade).

 **NOTE: The features listed in bold in the below table are new for iDRAC9.**

**Table 11. iDRAC feature comparison**

Features	iDRAC8 Basic	iDRAC9 Basic	iDRAC8 Express	iDRAC9 Express	iDRAC8 Express for Blades	iDRAC9 Express for Blades	iDRAC8 Enterprise	iDRAC9 Enterprise
Interface/Standards								
Redfish	Yes	Yes	Yes	Yes	Yes	Yes	Yes	Yes
IPMI 2.0	Yes	Yes	Yes	Yes	Yes	Yes	Yes	Yes
DCMI 1.5	Yes	Yes	Yes	Yes	Yes	Yes	Yes	Yes
Web-based GUI	Yes	Yes	Yes	Yes	Yes	Yes	Yes	Yes
Racadm command line—local/remote	Yes	Yes	Yes	Yes	Yes	Yes	Yes	Yes
SMASH-CLP—SSH-only	Yes	Yes	Yes	Yes	Yes	Yes	Yes	Yes
Telnet	Yes	Yes	Yes	Yes	Yes	Yes	Yes	Yes
SSH	Yes	Yes	Yes	Yes	Yes	Yes	Yes	Yes
Serial redirection	Yes	Yes	Yes	Yes	Yes	Yes	Yes	Yes
WSMAN	Yes	Yes	Yes	Yes	Yes	Yes	Yes	Yes
Network Time Protocol	No	No	Yes	Yes	Yes	Yes	Yes	Yes
Connectivity								
Shared NIC	Yes	Yes	Yes	Yes	N/A	N/A	Yes	Yes
Dedicated NIC	Yes	Yes	Yes	Yes	Yes	Yes	Yes	Yes
VLAN tagging	Yes	Yes	Yes	Yes	Yes	Yes	Yes	Yes
IPv4	Yes	Yes	Yes	Yes	Yes	Yes	Yes	Yes
IPv6	Yes	Yes	Yes	Yes	Yes	Yes	Yes	Yes
DHCP (new default; no static IP)	Yes	<b>Yes</b>	Yes	<b>Yes</b>	Yes	<b>Yes</b>	Yes	<b>Yes</b>
DHCP with Zero Touch	No	No	No	No	No	No	No	<b>Yes</b>
Dynamic DNS	Yes	Yes	Yes	Yes	Yes	Yes	Yes	Yes
OS pass-through	Yes	Yes	Yes	Yes	Yes	Yes	Yes	Yes
iDRAC Direct-Front panel USB	Yes	Yes	Yes	Yes	Yes	Yes	Yes	Yes
<b>Connection View</b>	No	<b>Yes</b>	No	<b>Yes</b>	No	<b>Yes</b>	No	<b>Yes</b>
<b>NFS v4</b>	No	<b>Yes</b>	No	<b>Yes</b>	No	<b>Yes</b>	No	<b>Yes</b>
<b>NTLM v1 and NTLM v2</b>	No	<b>Yes</b>	No	<b>Yes</b>	No	<b>Yes</b>	No	<b>Yes</b>
Security								

Features	iDRAC8 Basic	iDRAC9 Basic	iDRAC8 Express	iDRAC9 Express	iDRAC8 Express for Blades	iDRAC9 Express for Blades	iDRAC8 Enterprise	iDRAC9 Enterprise
Role-based authority	Yes	Yes	Yes	Yes	Yes	Yes	Yes	Yes
Local users	Yes	Yes	Yes	Yes	Yes	Yes	Yes	Yes
SSL encryption	Yes	Yes	Yes	Yes	Yes	Yes	Yes	Yes
IP blocking	No	No	Yes	Yes	Yes	Yes	Yes	Yes
Directory services—AD, LDAP	No	No	No	No	No	No	Yes	Yes
Two-factor authentication	No	No	No	No	No	No	Yes	Yes
Single sign-on	No	No	No	No	No	No	Yes	Yes
PK authentication	No	No	Yes	Yes	Yes	Yes	Yes	Yes
FIPS 140-2	Yes	Yes	Yes	Yes	Yes	Yes	Yes	Yes
<b>Secure UEFI boot-certificate management</b>	No	<b>Yes</b>	No	<b>Yes</b>	No	<b>Yes</b>	No	<b>Yes</b>
<b>Lock down mode</b>	No		No	No	No	No	No	<b>Yes</b>
<b>Unique iDRAC default password</b>	No	<b>Yes</b>	No	<b>Yes</b>	No	<b>Yes</b>	No	<b>Yes</b>
<b>Customizable Security Policy Banner-login page</b>	No	<b>Yes</b>	No	<b>Yes</b>	No	<b>Yes</b>	No	<b>Yes</b>
Remote Presence								
Power control	Yes	Yes	Yes	Yes	Yes	Yes	Yes	Yes
Boot control	Yes	Yes	Yes	Yes	Yes	Yes	Yes	Yes
Serial-over-LAN	Yes	Yes	Yes	Yes	Yes	Yes	Yes	Yes
Virtual Media	No	No	No	No	Yes	Yes	Yes	Yes
Virtual Folders	No	No	No	No	No	No	Yes	Yes
Remote File Share	No	No	No	No	No	No	Yes	Yes
Virtual Console	No	No	No	No	Yes	Yes	Yes	Yes
HTML5 access to virtual console	No	No	No	No	Yes	Yes	Yes	Yes
VNC connection to OS	No	No	No	No	No	No	Yes	Yes
Quality/bandwidth control	No	No	No	No	No	No	Yes	Yes
Virtual Console collaboration—6 users	No	No	No	No	No	No	Yes	Yes
Virtual Console chat	No	No	No	No	No	No	Yes	Yes
Virtual Flash partitions	No	No	No	No	No	No	Yes	Yes
<b>Group manager</b>	No	No	No	No	No	No	No	<b>Yes</b>
<b>HTTP/HTTPS support along with NFS/CIFS</b>	No	<b>Yes</b>	No	<b>Yes</b>	No	<b>Yes</b>	No	Yes
Power and Thermal								

Features	iDRAC8 Basic	iDRAC9 Basic	iDRAC8 Express	iDRAC9 Express	iDRAC8 Express for Blades	iDRAC9 Express for Blades	iDRAC8 Enterprise	iDRAC9 Enterprise
Real-time power meter	Yes	Yes	Yes	Yes	Yes	Yes	Yes	Yes
Power thresholds & alerts	No	No	Yes	Yes	Yes	Yes	Yes	Yes
Real-time power graphing	No	No	Yes	Yes	Yes	Yes	Yes	Yes
Historical power counters	No	No	Yes	Yes	Yes	Yes	Yes	Yes
Power capping	No	No	No	No	No	No	No	No
Power Center integration	No	No	No	No	No	No	Yes	Yes
Temperature monitoring	Yes	Yes	Yes	Yes	Yes	Yes	Yes	Yes
Temperature graphing	No	No	Yes	Yes	Yes	Yes	Yes	Yes
Health Monitoring								
Predictive failure monitoring	Yes	Yes	Yes	Yes	Yes	Yes	Yes	Yes
SNMPv1, v2 and v3—traps and gets	Yes	Yes	Yes	Yes	Yes	Yes	Yes	Yes
Email alerting	No	No	Yes	Yes	Yes	Yes	Yes	Yes
Configurable thresholds	Yes	Yes	Yes	Yes	Yes	Yes	Yes	Yes
Fan monitoring	Yes	Yes	Yes	Yes	Yes	Yes	Yes	Yes
Power Supply monitoring	Yes	Yes	Yes	Yes	Yes	Yes	Yes	Yes
Memory monitoring	Yes	Yes	Yes	Yes	Yes	Yes	Yes	Yes
CPU monitoring	Yes	Yes	Yes	Yes	Yes	Yes	Yes	Yes
RAID monitoring	Yes	Yes	Yes	Yes	Yes	Yes	Yes	Yes
NIC monitoring	Yes	Yes	Yes	Yes	Yes	Yes	Yes	Yes
HD monitoring—enclosure	Yes	Yes	Yes	Yes	Yes	Yes	Yes	Yes
Out of Band Performance Monitoring	No	No	No	No	No	No	Yes	Yes
<b>Alerts for excessive SSD wear</b>	No	<b>Yes</b>	No	<b>Yes</b>	No	<b>Yes</b>	No	<b>Yes</b>
<b>Customizable settings for Exhaust Temperature</b>	No	<b>Yes</b>	No	<b>Yes</b>	No	<b>Yes</b>	No	<b>Yes</b>
Update								
Remote agent-free update	Yes	Yes	Yes	Yes	Yes	Yes	Yes	Yes
Embedded update tools	Yes	Yes	Yes	Yes	Yes	Yes	Yes	Yes
Sync with repository—scheduled updates	No	No	No	No	No	No	Yes	Yes
Auto update	No	No	No	No	No	No	Yes	Yes
<b>Improved PSU firmware updates</b>	No	<b>Yes</b>	No	<b>Yes</b>	No	<b>Yes</b>	No	<b>Yes</b>
Deployment and Configuration								

Features	iDRAC8 Basic	iDRAC9 Basic	iDRAC8 Express	iDRAC9 Express	iDRAC8 Express for Blades	iDRAC9 Express for Blades	iDRAC8 Enterprise	iDRAC9 Enterprise
Local configuration via F10	Yes	Yes	Yes	Yes	Yes	Yes	Yes	Yes
Embedded OS deployment tools	Yes	Yes	Yes	Yes	Yes	Yes	Yes	Yes
Embedded configuration tools	Yes	Yes	Yes	Yes	Yes	Yes	Yes	Yes
AutoDiscovery	No	No	Yes	Yes	Yes	Yes	Yes	Yes
Remote OS deployment	No	No	Yes	Yes	Yes	Yes	Yes	Yes
Embedded driver pack	Yes	Yes	Yes	Yes	Yes	Yes	Yes	Yes
Full configuration inventory	Yes	Yes	Yes	Yes	Yes	Yes	Yes	Yes
Inventory export	Yes	Yes	Yes	Yes	Yes	Yes	Yes	Yes
Remote configuration	Yes	Yes	Yes	Yes	Yes	Yes	Yes	Yes
Zerotouch configuration	No	No	No	No	No	No	Yes	Yes
System Retire/Repurpose	Yes	Yes	Yes	Yes	Yes	Yes	Yes	Yes
<b>Server Configuration Profile in GUI</b>	No	<b>Yes</b>	No	<b>Yes</b>	No	<b>Yes</b>	No	<b>Yes</b>
Diagnostics, Service and Logging								
Embedded diagnostic tools	Yes	Yes	Yes	Yes	Yes	Yes	Yes	Yes
Part Replacement	No	No	Yes	Yes	Yes	Yes	Yes	Yes
Server Configuration Backup	No	No	No	No	No	No	Yes	Yes
Server Configuration Restore	Yes	Yes	Yes	Yes	Yes	Yes	Yes	Yes
Easy Restore—system configuration	Yes	Yes	Yes	Yes	Yes	Yes	Yes	Yes
<b>Easy Restore Auto Timeout</b>	No	<b>Yes</b>	No	<b>Yes</b>	No	<b>Yes</b>	No	<b>Yes</b>
<b>LED health status indicator</b>	Yes	Yes	Yes	Yes	Yes	Yes	Yes	Yes
iDRAC Direct—front USB mgmt port	Yes	Yes	Yes	Yes	Yes	Yes	Yes	Yes
<b>iDRAC Service Module (ISM) embedded</b>	No	<b>Yes</b>	No	<b>Yes</b>	No	<b>Yes</b>	No	<b>Yes</b>
<b>ISM to inband alert forwarding to consoles</b>	No	<b>Yes</b>	No	<b>Yes</b>	No	<b>Yes</b>	No	<b>Yes</b>
Crash screen capture	No	No	Yes	Yes	Yes	Yes	Yes	Yes
Crash video capture	No	No	No	No	No	No	Yes	Yes
Boot capture	No	No	No	No	No	No	Yes	Yes
Manual reset for iDRAC—LCD ID button	Yes	Yes	Yes	Yes	Yes	Yes	Yes	Yes

Features	iDRAC8 Basic	iDRAC9 Basic	iDRAC8 Express	iDRAC9 Express	iDRAC8 Express for Blades	iDRAC9 Express for Blades	iDRAC8 Enterprise	iDRAC9 Enterprise
Remote reset for iDRAC—requires iSM	Yes	Yes	Yes	Yes	Yes	Yes	Yes	Yes
Virtual NMI	Yes	Yes	Yes	Yes	Yes	Yes	Yes	Yes
OS watchdog	Yes	Yes	Yes	Yes	Yes	Yes	Yes	Yes
SupportAssist Report—embedded	Yes	Yes	Yes	Yes	Yes	Yes	Yes	Yes
System Event Log	Yes	Yes	Yes	Yes	Yes	Yes	Yes	Yes
Lifecycle Log	Yes	Yes	Yes	Yes	Yes	Yes	Yes	Yes
Enhanced logging in the Lifecycle controller log	Yes	Yes	Yes	Yes	Yes	Yes	Yes	Yes
Work notes	Yes	Yes	Yes	Yes	Yes	Yes	Yes	Yes
Remote Syslog	No	No	No	No	No	No	Yes	Yes
License management	Yes	Yes	Yes	Yes	Yes	Yes	Yes	Yes
Improved customer experience								
<b>iDRAC -Faster processor, more memory</b>	No	<b>Yes</b>	No	<b>Yes</b>	No	<b>Yes</b>	No	<b>Yes</b>
<b>GUI rendered in HTML5</b>	No	<b>Yes</b>	No	<b>Yes</b>	No	<b>Yes</b>	No	<b>Yes</b>
<b>Add BIOS configuration to iDRAC GUI</b>	No	<b>Yes</b>	No	<b>Yes</b>	No	<b>Yes</b>	No	<b>Yes</b>
<b>iDRAC support for SW RAID licensing</b>	No	<b>Yes</b>	No	<b>Yes</b>	No	<b>Yes</b>	No	<b>Yes</b>

## Agent-free management

As Dell EMC PowerEdge servers have embedded server lifecycle management, in many cases, there is no need to install an OpenManage systems management software agent into the operating system of a Dell EMC PowerEdge server. This greatly simplifies and streamlines the management footprint.

## Agent-based management

Most systems management solutions require pieces of software, called agents, to be installed on each node in order to be managed within the IT environment. Additionally, the same agent is often used as a local interface into the hardware health and may be accessed remotely as a management interface, typically referred to as a one-to-one interface. For customers that continue to use agent-based solutions, Dell EMC provides OpenManage Server Administrator.

## Dell EMC consoles

The central console in a systems management solution is often referred to as the one-to-many console. The central console provides a rapid view and insight into the overall health of all systems in the IT environment. The Dell EMC systems management portfolio includes several powerful consoles, depending upon your needs, including the following:

### Dell EMC OpenManage Essentials

OpenManage Essentials is the one-to-many management console for monitoring Dell HW infrastructure including server, storage and networking, as well as for lifecycle management of PowerEdge servers. It support Windows, Linux, VMware, and HyperV environments. OME provides a simple and easy interface for system administrators to maximize the uptime and health of Dell systems. It helps to

- Monitor health status and events for PowerEdge servers, EqualLogic or MD series storage, and PowerConnect and Force 10 switches.
- Provide hardware-level control and management for PowerEdge server, blade system, and internal storage arrays.
- Link and Launch element management interfaces, such as, iDRAC, CMC, EQL group manager etc
- Integrate with the following Dell solutions:
  - Dell Repository Manager : Builds customized server update baselines that OpenManage Essentials can use.
  - OpenManage Power Center : Optimize power consumption in the servers.
  - SupportAssist : Enables automatic hardware failure notification to be sent securely to Dell EMC technical support for intelligent analysis and diagnosis to optimize availability and reduce manual intervention. This solution is available as part of Basic Hardware Warranty, ProSupport and ProSupport Plus at no additional cost. Download SupportAssist Enterprise from [Dell.com/SupportAssist](http://Dell.com/SupportAssist).
- Provide REST interface API support for 3rd Party Integration.
- Manage Server Configuration - it is a fee-based license available on Dell's 14th generation of PowerEdge servers with iDRAC Enterprise or iDRAC Express licenses. The key features include the following:
  - Configure a server or chassis using a template and deploying an operating system on the PowerEdge bare metal servers.
  - During a server operation, automatically detect and notify any server or chassis drift from a customer-defined baseline configuration.
  - Boot a system from a network-mounted ISO using iDRAC.
  - Replicate of FN-IOM and M-IOA configurations within M1000e chassis.
  - Support VLAN Management for FN-IOM and M-IOA.
- For more information, see [delltechcenter.com/OME](http://delltechcenter.com/OME)

## OpenManage Mobile

OpenManage Mobile(OMM) is a software application that enables easy, convenient, and secure monitoring and management of PowerEdge servers remotely, or at-the-server. With OpenManage Mobile, IT Administrators can securely perform several data center monitoring and remediation tasks using an Android or iOS mobile device. The OpenManage Mobile app is available as a free software download from the Apple Store and the Google Play Store.

OMM can also monitor and manage PowerEdge servers through a OpenManage Essentials console or by directly accessing the server's iDRAC.

The OpenManage Essentials console can be accessed through OpenManage Mobile over a secure IP network. This allows you to monitor all devices managed by OpenManage Essentials such as Dell EMC servers, storage, networking, firewall, and supported third party devices.

If you are remote, you can access iDRAC over a secure IP network.

Key Features of OpenManage Mobile (When connected through OpenManage Essentials console):

- Connect to multiple servers which have OME installed, from a single mobile device.
- Connect to multiple servers individually through the iDRAC interface.
- Receive critical alert notification on your mobile device as they arrive into your OpenManage Essentials management console.
- Acknowledge, forward, and delete alerts from your mobile device.
- Browse through device details, firmware inventory, and event logs of individual systems.
- Perform several server management functions such as power-on, power cycle, reboot, and shutdown from the mobile application.

Key Features of OpenManage Mobile (When connected through iDRAC):

- Connect to any 14th gen, 13th gen, or 12th gen server remotely
- Assign IP address, change credentials, and update common BIOS attributes for Bare Metal Configuration
- Configure one server manually, or multiple servers simultaneously through a template.
- Browse server details, health status, hardware & firmware inventory, networking details, and System Event or LC logs. Share this information easily with other IT Administrators.
- Access SupportAssist reports, Last Crash screen and video (PowerEdge 14th gen servers)
- Access Virtual Console (and reduce the need for crash carts).
- Power On, Shut down, or Reboot your server from anywhere.
- Run any RACADM command

### **OpenManage Power Center**

OpenManage Power Center is a one-to-many application that can read power usage and thermal readings information from Dell EMC servers, Power Distribution Units (PDU), and Uninterruptible Power Supplies (UPS). It can aggregate this information into rack, row, and room-level views.

For more information, see OpenManage Power Center User's Guide available at [Dell.com/openmanagemanuals](http://Dell.com/openmanagemanuals).

## **Dell EMC OpenManage systems management tools, utilities and protocols**

Dell EMC OpenManage systems management tools and utilities consist of the following:

### **Dell EMC Repository Manager:**

Dell EMC Repository Manager (DRM) is an application that helps you to:

- Identify the updates that are relevant to the systems in your data center.
- Identify and notify when updates are available.
- Package the updates into different deployment format.

To automate the creation of baseline repositories, DRM provides advanced integration capabilities with iDRAC/LC, OpenManage Essentials, Chassis Management Controller, OpenManage Integration for VMware vCenter and OpenManage Integration for Microsoft System Center (OMIMSSC). Also, DRM packages updates into custom catalogs that can be used for deployment.

Dell EMC Repository Manager can create the following deployment tools:

- Custom catalogs
- Lightweight deployment pack
- Bootable Linux ISO
- Custom Server Update Utility (SUU)

For more information, see Dell EMC Repository Manager User's Guide available at [Dell.com/support/manuals](http://Dell.com/support/manuals).

### **Dell Update Packages**

Dell Update Packages (DUP) is a self-contained executable supported by Microsoft Windows or Linux that updates a component on a server and applications like OMSA, iSM, and DSET.

DUPs can be executed in GUI or in CLI mode.

For more information, see Dell EMC Update Packages User's Guide available at [www.delltechcenter.com/DSU](http://www.delltechcenter.com/DSU).

### **Dell Remote Access Controller Administration (RACADM) CLI**

The RACADM command-line utility provides a scriptable interface to perform inventory, configuration, update, and health status check of PowerEdge servers. RACADM operates in multiple modes:

- Local — supports running RACADM commands from the managed server's operating system.
- SSH or Telnet — known as Firmware RACADM; is accessible by logging in to iDRAC using SSH or Telnet
- Remote — supports running RACADM commands from a remote management station such as a laptop or desktop.

RACADM is supported by the iDRAC with Lifecycle Controller and by the Chassis Management Controller of the M1000e, VRTX and FX2 modular systems. Local and Remote RACADM is supported on Windows Server, Windows clients, and on Red Hat, SuSe and Ubuntu Linux.

For more information, see the RACADM Command Line Reference Guide for iDRAC and CMC available at [Dell.com/support/manuals](http://Dell.com/support/manuals).

### **iDRAC with Lifecycle Controller Embedded Management APIs**

iDRAC with Lifecycle Controller provides a range of standards-based applications programming interfaces (APIs) that enable scalable and automated management of PowerEdge servers. Standard systems management APIs have been developed by organizations such as the Institute of Electrical and Electronics Engineers (IEEE) and Distributed Management Task Force (DMTF). These APIs are widely used by commercial systems management products and by custom programs and scripts developed by IT staff to automate management functions such as discovery, inventory, health status checking, configuration, update, and power management. The APIs supported by iDRAC with Lifecycle Controller include:

- **Redfish** - In 2015, the DMTF Scalable Platforms Management Forum published Redfish, an open industry-standard specification and schema designed to meet the needs of IT administrators for simple, modern, and secure management of scalable platform hardware. Dell is a key contributor to the Redfish standard, acting as co-chair of the SPMF, promoting the benefits of Redfish, and working to deliver those benefits within industry-leading systems management solutions. Redfish is a next generation management standard using a data model representation inside a hypermedia RESTful interface. The data model is defined in terms of a standard, machine-readable schema, with the payload of the messages expressed in JSON and the OData v4 protocol.
- **WSMan** -The Web Services For Management (WSMan) API, first published by the DMTF in 2008, is the most mature and robust API provided by iDRAC with Lifecycle Controller. WSMan uses a Simple Object Access Protocol (SOAP) with data modeled using the Common Information Model. WSMan provides interoperability between management applications and managed resources, and identifies a core set of web service specifications and usage requirements that expose a common set of operations central to all systems management.
- **IPMI** - The Intelligent Platform Management Interface (IPMI) is a message-based, hardware-level interface specification that can operate over both LAN and serial interfaces. IPMI is supported broadly by server vendors, systems management solutions, and open source software.
- **SNMP** - The Simple Network Management Protocol (SNMP) helps in standardizing the management of network devices. SNMP allows commercial management consoles created for monitoring network switches and routers to also monitor X86 servers. SNMP is primarily used to deliver event messages to alert administrators of problems on their systems but can also be used to discover, inventory and configure servers.

To assist automating system management tasks and simplify API integration, Dell provides PowerShell and Python libraries and script examples utilizing the WSMan interface. The iDRAC with LC pages of Dell Techcenter offer a library of technical white papers detailing the use of the embedded management APIs. For more information, see [delltechcenter.com/iDRAC](http://delltechcenter.com/iDRAC) and [delltechcenter.com/LC](http://delltechcenter.com/LC).

## **Integration with third-party consoles**

Dell EMC OpenManage provides integration with several leading third-party consoles, including:

### **OpenManage Integration Suite for Microsoft System Center**

The combination of Dell OpenManage Integration Suite and Microsoft System Center simplifies and enhances deployment, configuration, monitoring and updating of Dell servers and storage in physical and virtual environments. Our agent-free and agent-based plug-ins deliver a unique level of integration and efficiency when managing Dell hardware within a System Center environment.

The OpenManage Integration Suite for Microsoft System Center includes: Dell Server and Storage Management Packs for System Center Operations Manager (SCOM); Dell Server Deployment Packs and Update Catalogs for System Center Configuration



Manager (SCCM); and tools for optimizing management of Dell PowerEdge servers in virtual environments using System Center Virtual Machine Manager (SCVMM).

### **OpenManage Integration for VMware vCenter**

The OpenManage Integration for VMware vCenter allows you to monitor, provision, and manage PowerEdge server hardware and firmware. You can perform these tasks through a dedicated Dell menu that can be accessed directly through the VMware vCenter console. OMIVV also allows granular control and reporting for the hardware environment using the same role-based access control model as vCenter. The OpenManage Management Pack for vRealize Operations Manager is available with OMIVV v4.0 onwards. This helps in checking hardware health and alerting into vRealize operations, which also includes dashboard and reporting on the server environment.

You can manage and monitor Dell hardware within the virtualized environment

- Alerting and monitoring environment for servers and chassis
- Monitoring and reporting for servers and chassis
- Updating firmware on servers
- Deploying enhanced options

For more information, see [delltechcenter.com/omivv](http://delltechcenter.com/omivv)

 **NOTE: The Dell EMC Repository Manager integrates with OpenManage Integration for VMware vCenter. The Dell EMC Repository Manager provides advanced functionality, simplifies the discovery, and deployment of new updates.**

### **BMC Software**

Dell EMC and BMC Software work together to simplify IT by ensuring tight integration between Dell EMC server, storage, and network management functionality and the BMC Software process and data center automation products.

## **OpenManage connections with third-party consoles**

Dell EMC OpenManage Connections gives you an easy path to adding support for third-party devices, so you can continue to use your existing management tools while easily adding Dell EMC server systems to your existing IT environment. Integrate new systems at your own pace. Manage new Dell EMC servers and storage with your legacy management tools, while extending the useful life of your existing resources. With OpenManage Connections you can add monitoring and troubleshooting of Dell EMC assets to your IT infrastructure.

- OpenManage Connection for Nagios Core and Nagios XI
- OpenManage Connection for HPE Operations Manager i (OMi)

For more information on these OpenManage Connections, visit [Dell.com/openmanage](http://Dell.com/openmanage).

# Appendix A. Additional specifications

## Chassis dimensions

This section describes the physical dimensions of the system.

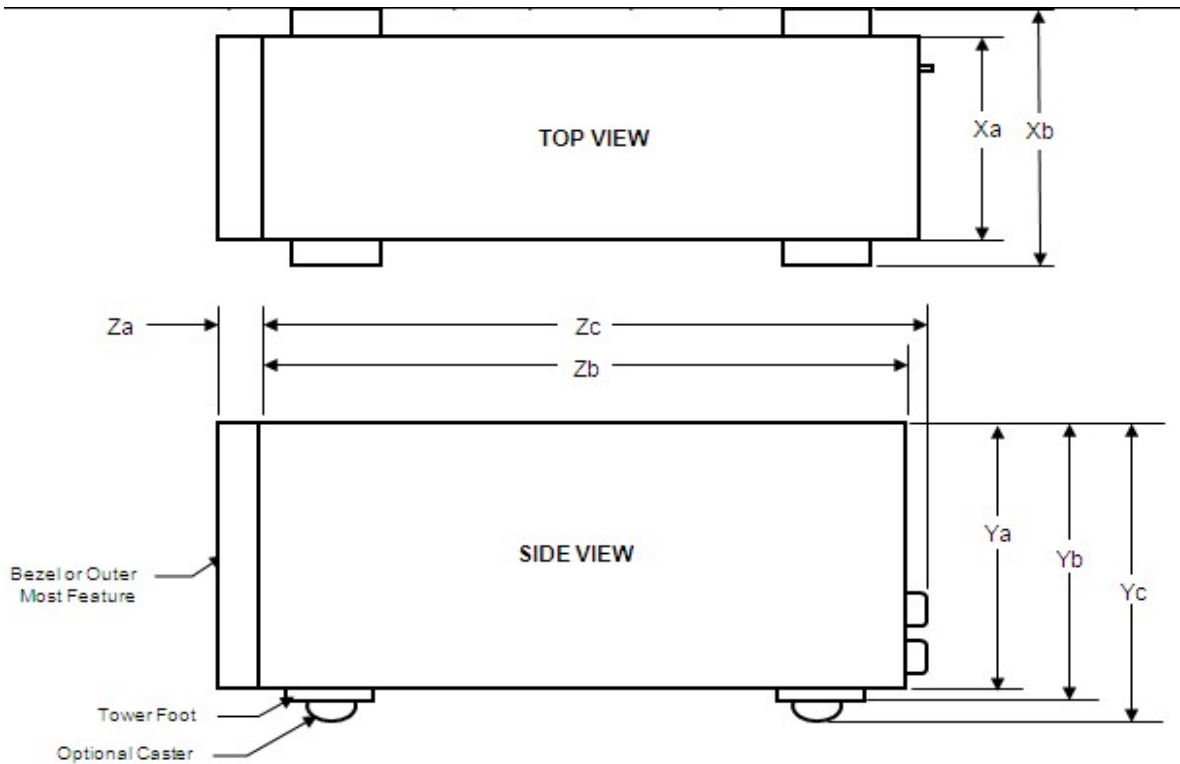

**Figure 6. Chassis dimensions of the PowerEdge T140 system**

The following table shows the dimension details of the PowerEdge T140:

Xa	Xb	Ya	Yb	Yc	Za with bezel	Za without bezel	Zb*	Zc	Max Sys Wgt (Kg)
175 mm (6.89 inches)	N/A	360 mm (14.17 inches)	362.9 mm (14.29 inches)	N/A	35.0mm (1.38 inches)	N/A	400.0 mm (15.75 inches)	418.75 mm (16.49 inches)	11.84

## Video

The following list the video specifications for the PowerEdge T140:

- Video type: Integrated Matrox G200 with iDRAC9
- Video memory: 16 MB shared with iDRAC9 application memory

## USB ports

The PowerEdge T140 supports the USB ports mentioned below:

**Table 12. USB specifications**

System	PowerEdge T140
Front panel	<ul style="list-style-type: none"><li>• 1 USB 3.0</li><li>• 1 Micro USB 2.0 (dedicated iDRAC direct)</li></ul>
Back panel	<ul style="list-style-type: none"><li>• 2 USB 3.0</li><li>• 4 USB 2.0</li></ul>
Internal	One USB 3.0-compliant port

## Hard drives

The PowerEdge T140 supports SAS, SATA, Nearline SAS drives/SSD drives. The supported hard drive configuration is 4 x 3.5-inch cabled configuration.

The following table shows the supported hard drive and capacity:

Feature	Description
Hard drives	<ul style="list-style-type: none"><li>• 3.5" Enterprise SATA 7.2K HDDs</li><li>• 3.5" Near Line SAS 7.2K HDDs</li><li>• 3.5" 7.2K SATA Client Drives</li></ul>
Capacity	<ul style="list-style-type: none"><li>• 1 TB</li><li>• 2 TB</li><li>• 4 TB</li></ul>



**NOTE: 4TB requires PERC H330 or H730P**

## NIC ports

The PowerEdge T140 supports two 10/100/1000 Mbps NIC ports at the back panel.

## Environmental specifications

This section includes the environmental specifications for the PowerEdge T140:

Feature	Descriptions
Temperature	<ul style="list-style-type: none"><li>• Maximum temperature gradient (Operating and storage)<ul style="list-style-type: none"><li>– 20 °C/h (36 °F/h)</li></ul></li><li>• Storage temperature limits<ul style="list-style-type: none"><li>– -40 °C to 65 °C (-40 °F to 149 °F)</li></ul></li></ul>
Relative humidity	<ul style="list-style-type: none"><li>• 5% to 95% RH with 33 °C (91 °F) maximum dew point. Atmosphere must be noncondensing at all times.</li></ul>
Temperature (continuous operation)	<ul style="list-style-type: none"><li>• Temperature ranges (for altitude less than 950 m or 3117 ft)</li></ul>

Feature	Descriptions
<b>Maximum vibration</b>	<ul style="list-style-type: none"> <li>– 10 °C to 35 °C (50 °F to 95 °F) with no direct sunlight on the equipment.</li> <li>• Humidity percentage range <ul style="list-style-type: none"> <li>– 10% to 80% Relative Humidity with 29 °C(84.2 °F) maximum dew point.</li> </ul> </li> <li>• Operating <ul style="list-style-type: none"> <li>– 0.26 Grms at 5 Hz to 350 Hz (operationorientation).</li> </ul> </li> <li>• Storage <ul style="list-style-type: none"> <li>– 1.88 Grms at 10 Hz to 500 Hz for 15 min (allsix sides tested).</li> </ul> </li> </ul>
<b>Maximum shock</b>	<ul style="list-style-type: none"> <li>• Operating <ul style="list-style-type: none"> <li>– Six consecutively executed shock pulses in the positive and negative x, y, and z axes of 31 G for up to 2.6 ms.</li> </ul> </li> <li>• Storage <ul style="list-style-type: none"> <li>– One pulse on each side of the system of 71 G up to 2 ms.</li> </ul> </li> </ul>
<b>Maximum altitude</b>	<ul style="list-style-type: none"> <li>• Operating <ul style="list-style-type: none"> <li>– 3,048 m (10,000 ft)</li> </ul> </li> <li>• Storage <ul style="list-style-type: none"> <li>– 12,000 m (39,370 ft)</li> </ul> </li> </ul>
<b>Operating Altitude De-rating, Up to 35 °C (95 °F)</b>	<ul style="list-style-type: none"> <li>• Maximum temperature is reduced by 1°C/300 m (1 °F/547 ft) above 950 m (3,117 ft).</li> </ul>

## Appendix B. Standards compliance

The system conforms to the following industry standards.

**Table 13. Industry standard documents**

Standard	URL for information and specifications
<b>ACPI</b> Advance Configuration and Power Interface Specification, v2.0c	<a href="http://acpi.info">acpi.info</a>
<b>Ethernet</b> IEEE 802.3-2005	<a href="http://standards.ieee.org/getieee802/802.3.html">standards.ieee.org/getieee802/802.3.html</a>
<b>HDG</b> Hardware Design Guide Version 3.0 for Microsoft Windows Server	<a href="http://microsoft.com/whdc/system/platform/pcdesign/designguide/serverdg.mspx">microsoft.com/whdc/system/platform/pcdesign/designguide/serverdg.mspx</a>
<b>IPMI</b> Intelligent Platform Management Interface, v2.0	<a href="http://intel.com/design/servers/ipmi">intel.com/design/servers/ipmi</a>
<b>DDR4 Memory</b> DDR4 SDRAM Specification	<a href="http://jedec.org/standards-documents/docs/jesd79-4.pdf">jedec.org/standards-documents/docs/jesd79-4.pdf</a>
<b>PCI Express</b> PCI Express Base Specification Rev. 2.0 and 3.0	<a href="http://pcisig.com/specifications/pciexpress">pcisig.com/specifications/pciexpress</a>
<b>PMBus</b> Power System Management Protocol Specification, v1.2	<a href="http://pmbus.info/specs.html">pmbus.info/specs.html</a>
<b>SAS</b> Serial Attached SCSI, v1.1	<a href="http://t10.org">t10.org</a>
<b>SATA</b> Serial ATA Rev. 2.6; SATA II, SATA 1.0a Extensions, Rev. 1.2	<a href="http://sata-io.org">sata-io.org</a>
<b>SMBIOS</b> System Management BIOS Reference Specification, v2.7	<a href="http://dmtf.org/standards/smbios">dmtf.org/standards/smbios</a>
<b>TPM</b> Trusted Platform Module Specification, v1.2 and v2.0	<a href="http://trustedcomputinggroup.org">trustedcomputinggroup.org</a>
<b>UEFI</b> Unified Extensible Firmware Interface Specification, v2.1	<a href="http://uefi.org/specifications">uefi.org/specifications</a>
<b>USB</b> Universal Serial Bus Specification, Rev. 2.0	<a href="http://usb.org/developers/docs">usb.org/developers/docs</a>

# Appendix C Additional resources

**Table 14. Additional resources**

Resource	Description of contents	Location
Installation and Service Manual	<p>This manual, available in PDF format, provides the following information:</p> <ul style="list-style-type: none"> <li>· Chassis features</li> <li>· System Setup program</li> <li>· System messages</li> <li>· System codes and indicators</li> <li>· System BIOS</li> <li>· Remove and replace procedures</li> <li>· Troubleshooting</li> <li>· Diagnostics</li> <li>· Jumpers and connectors</li> </ul>	<a href="http://Dell.com/Support/Manuals">Dell.com/Support/Manuals</a>
Getting Started Guide	<p>This guide ships with the system, and is also available in PDF format. This guide provides the following information:</p> <ul style="list-style-type: none"> <li>· Initial setup steps</li> <li>· Key system features</li> <li>· Technical specifications</li> </ul>	<a href="http://Dell.com/Support/Manuals">Dell.com/Support/Manuals</a>
Rack Installation Instructions	This document ships with the rack kits, and provides instructions for installing a server in a rack.	<a href="http://Dell.com/Support/Manuals">Dell.com/Support/Manuals</a>
Information Update	This document ships with the system, is also available in PDF format online, and provides information on system updates.	<a href="http://Dell.com/Support/Manuals">Dell.com/Support/Manuals</a>
System Information Label	The system information label documents the system board layout and system jumper settings. Text is minimized due to space limitations and translation considerations. The label size is standardized across platforms.	Inside the system chassis cover
Quick Resource Locator (QRL)	This code on the chassis can be scanned by a phone application to access additional information and resources for the server, including videos, reference materials, service tag information, and Dell EMC contact information.	Inside the system chassis cover
Energy Smart Solution Advisor (ESSA)	The Dell EMC online ESSA enables easier and more meaningful estimates to help you determine the most efficient configuration possible. Use ESSA to calculate the power consumption of your hardware, power infrastructure, and storage.	<a href="http://Dell.com/calc">Dell.com/calc</a>

## Appendix D. Support and deployment services

### ProDeploy Enterprise Suite and Residency Services

ProDeploy Enterprise Suite gets your server out of the box and into optimized production - fast. Our elite deployment engineers with broad and deep experience utilizing best-in-class processes along with our established global scale can help you around the clock and around the globe. From simple to the most complex server installations and software integration, we take the guess work and risk out of deploying your new server technology. Who's better suited to implement the latest Dell EMC servers than the Dell EMC elite deployment engineers who do it every day?

		Basic Deployment	ProDeploy	ProDeploy Plus
Pre-deployment	Single point of contact for project management		•	In-region
	Site readiness review		•	•
	Implementation planning		•	•
	Technology Service Manager (TSM) engagement for ProSupport Plus entitled devices			•
Deployment	Deployment service hours	Business hours	24x7	24x7
	Onsite hardware installation*	•	•	•
	Packaging materials disposal	•	•	•
	Install and configure system software		•	Onsite
	Project documentation with knowledge transfer		•	•
Post-deployment	Deployment verification		•	•
	Configuration data transfer to Dell EMC technical support		•	•
	30-days of post-deployment configuration assistance			•
	Training credits for Dell EMC Education Services			•

Figure 7. ProDeploy Enterprise Suite capabilities

 **NOTE: Hardware installation not applicable on selected software products.**

### ProDeploy Plus

From beginning to end, ProDeploy Plus provides the skill and scale needed to successfully execute demanding deployments in today's complex IT environments. Certified Dell EMC experts start with extensive environmental assessments and detailed migration planning and recommendations. Software installation includes set up of most versions of Dell EMC SupportAssist and OpenManage system management utilities. Post-deployment configuration assistance, testing, and product orientation help you rest easy knowing your systems have been deployed and integrated by the best.

### ProDeploy

ProDeploy provides full service installation and configuration of both server hardware and system software by certified deployment engineers including set up of most versions of Dell EMC SupportAssist and OpenManage system management utilities. To prepare for the deployment, we conduct a site readiness review and implementation planning. System testing, validation and full project documentation with knowledge transfer complete the process. We focus on getting you up and running so you can focus on your business and prepare for whatever comes next.

### Basic Deployment

Basic Deployment delivers worry-free professional installation of your servers by experienced technicians who know Dell EMC servers inside and out.

## Residency Services

Residency helps customers transition to new capabilities quickly through on-site or remote Dell EMC experts whose priorities and time you control. Residency experts can provide post implementation management and knowledge transfer related to a new technology acquisition or day-to-day operational management of the IT infrastructure.

## Deployment services

Deployment services details and exceptions can be found in service description documents at the Enterprise Configuration and Deployment page on [Dell.com](http://Dell.com).

## Remote Consulting Services

When you are in the final stages of your PowerEdge server implementation, you can rely on Dell Remote Consulting and our certified technical experts to help you optimize your configuration with best practices for your software, virtualization, server, storage, networking, and systems management.

## Data Migration Service

Protect your business and data with our single point of contact to manage your data migration project. Your project manager will work with our experienced team of experts to create a plan using industry-leading tools and proven processes based on global best practices to migrate your existing files and data, so your business gets up and running quickly and smoothly.

## ProSupport Enterprise Suite

With Dell EMC ProSupport Services, we can help you keep your operation running smoothly, so you can focus on running your business. We will help you maintain peak performance and availability of your most essential workloads. Dell EMC ProSupport is a suite of support services that enable you to build the solution that is right for your organization. Choose support models based on how you use technology and where you want to allocate resources. From the desktop to the data center, address everyday IT challenges, such as unplanned downtime, mission-critical needs, data and asset protection, support planning, resource allocation, software application management and more. Optimize your IT resources by choosing the right support model.

The image shows three distinct colored boxes, each representing a different ProSupport service level. The first box is blue and titled 'ProSupport Plus', the second is orange and titled 'ProSupport', and the third is green and titled 'ProSupport One for Data Center'. Each box contains a brief description of the service's benefits.

Service Level	Description
<b>ProSupport Plus</b>	Optimize your critical systems and free up staff to innovate the business. ProSupport Plus provides an assigned Technology Service Manager and access to senior technical engineers that quickly diagnose issues and provide personalized guidance to avoid problems before they ever impact your business.
<b>ProSupport</b>	Keep your hardware and software running smoothly with 24x7 access to technology engineers as well as proactive and preventive technologies to help you get ahead of issues.
<b>ProSupport One for Data Center</b>	Get a tailored, personalized support experience for your large IT environment, including an assigned service account management expert as well as flexible parts and labor options.

Figure 8. ProSupport Enterprise Suite



## ProSupport Plus

When you purchase your PowerEdge server, we recommend ProSupport Plus, our proactive and preventative support for your business-critical systems. ProSupport Plus provides you with all the benefits of ProSupport, plus the following:

- A designated Technology Service Manager who knows your business and your environment
- Access to senior ProSupport engineers for faster issue resolution
- Personalized, preventive recommendations based on analysis of support trends and best practices from across the Dell EMC customer base to reduce support issues and improve performance
- Predictive analysis for issue prevention and optimization enabled by SupportAssist
- Proactive monitoring, issue detection, notification and automated case creation for accelerated issue resolution enabled by SupportAssist
- On-demand reporting and analytics-based recommendations enabled by SupportAssist and TechDirect

## ProSupport

Our ProSupport service offers highly trained experts around the clock and around the globe to address your IT needs. We will help you minimize disruptions and maximize availability of your PowerEdge server workloads with:

- 24x7x365 access to certified hardware and software experts
- Collaborative 3rd party support
- Hypervisor and OS support
- Consistent level of support available for Dell EMC hardware, software and solutions
- Onsite parts and labor response options including next business day or four-hour mission critical

## ProSupport One for Data Center

ProSupport One for Data Center offers flexible site-wide support for large and distributed data centers with more than 1,000 assets. This offering is built on standard ProSupport components that leverage our global scale but are tailored to your company's needs. While not for everyone, it offers a truly unique solution for Dell EMC's largest customers with the most complex environments.

- Team of designated Technology Services Managers with remote, on-site options
- Designated ProSupport One technical and field engineers who are trained on your environment and configurations
- On-demand reporting and analytics-based recommendations enabled by SupportAssist and TechDirect
- Flexible on-site support and parts options that fit your operational model
- A tailored support plan and training for your operations staff

# Enterprise Support Services Feature Comparison

	ProSupport	ProSupport Plus	ProSupport One for Data Center
Remote technical support	24x7	24x7	24x7
Onsite support	Next business day or Mission Critical	Next business day or Mission Critical	Flexible
Automated issue detection and case creation	●	●	●
Self-service case initiation and management	●	●	●
Hypervisor, Operating Environment Software and OS support	●	●	●
Priority access to specialized support experts		●	●
Designated Technology Service Manager		●	●
Personalized assessments and recommendations		●	●
On-demand support and utilization reports		●	●
Systems Maintenance guidance		Semiannual	Optional
Designated technical and field support teams			●

Figure 9. ProSupport One for Data Center model

## Support Technologies

Powering your support experience with predictive, data-driven technologies.

### SupportAssist

The best time to solve a problem is before it happens. The automated proactive and predictive technology SupportAssist\* helps reduce your steps and time to resolution, often detecting issues before they become a crisis. Benefits include:

- Value - SupportAssist is available to all customer at no additional charge.
- Improve productivity - replace manual, high-effort routines with automated support.
- Accelerate time to resolution - receive issue alerts, automatic case creation and proactive contact from Dell EMC experts.
- Gain insight and control - optimize enterprise devices with on-demand ProSupport Plus reporting in TechDirect and get predictive issue detection before the problem starts.

SupportAssist is included with all support plans but features vary based on service level agreement.

	Basic Hardware Warranty	ProSupport	ProSupport Plus
Automated issue detection and system state information collection	●	●	●
Proactive, automated case creation and notification		●	●
Predictive issue detection for failure prevention			●
Recommendation reporting available on-demand in TechDirect			●

Figure 10. SupportAssist model

Get started at [Dell.com/SupportAssist](http://Dell.com/SupportAssist)

### TechDirect

Boost your IT teams productivity when supporting Dell EMC systems. With over 1.4 million self-dispatches processed each year, TechDirect has proven its effectiveness as a support tool. You can:

- Self-dispatch replacement parts

- Request technical support
- Integrate APIs into your help desk

Or, access all your Dell EMC certification and authorization needs. Train your staff on Dell EMC products as TechDirect allows you to:

- Download study guides
- Schedule certification and authorization exams
- View transcripts of completed courses and exams

Register at [techdirect.dell.com](http://techdirect.dell.com)

## **Additional professional services**

### **Dell Education Services**

Dell Education Services offers the PowerEdge server training courses designed to help you achieve more with your hardware investment. The curriculum is designed in conjunction with the server development team, as well as Dell EMC's technical support team, to ensure that the training delivers the information and practical, hands-on skills you and your team need to confidently manage and maintain your Dell EMC server solution. To learn more or register for a class today, visit [LearnDell.com/Server](http://LearnDell.com/Server).

### **Dell EMC Global Infrastructure Consulting Services**

Dell EMC Global Infrastructure Consulting Services use skilled solution architects, innovative tools, automated analysis and Dell EMC's intellectual property to give you rapid insight into the root causes of unnecessary complexity. We seek better answers than traditional service models, and our strategy is to help you quickly identify high-impact, short-duration projects that deliver return on investment (ROI) and free up resources. The results are practical, action-oriented plans with specific, predictable, measurable outcomes. From data center optimization to server virtualization to systems management, our consulting services can help you build a more efficient enterprise.

### **Dell EMC Managed Services**

Dell EMC Managed Services are a modular set of lifecycle services designed to help you automate and centrally configure, deploy, and manage your day-to-day data center operations. These services extend your existing on-premise IT infrastructure with off-premise cloud services designed to better address challenges with mobility, highly distributed organizations, security, compliance, business continuity, and disaster preparedness.